

KEL84

Integrated Valve amplifier

Signal circuit (one channel)

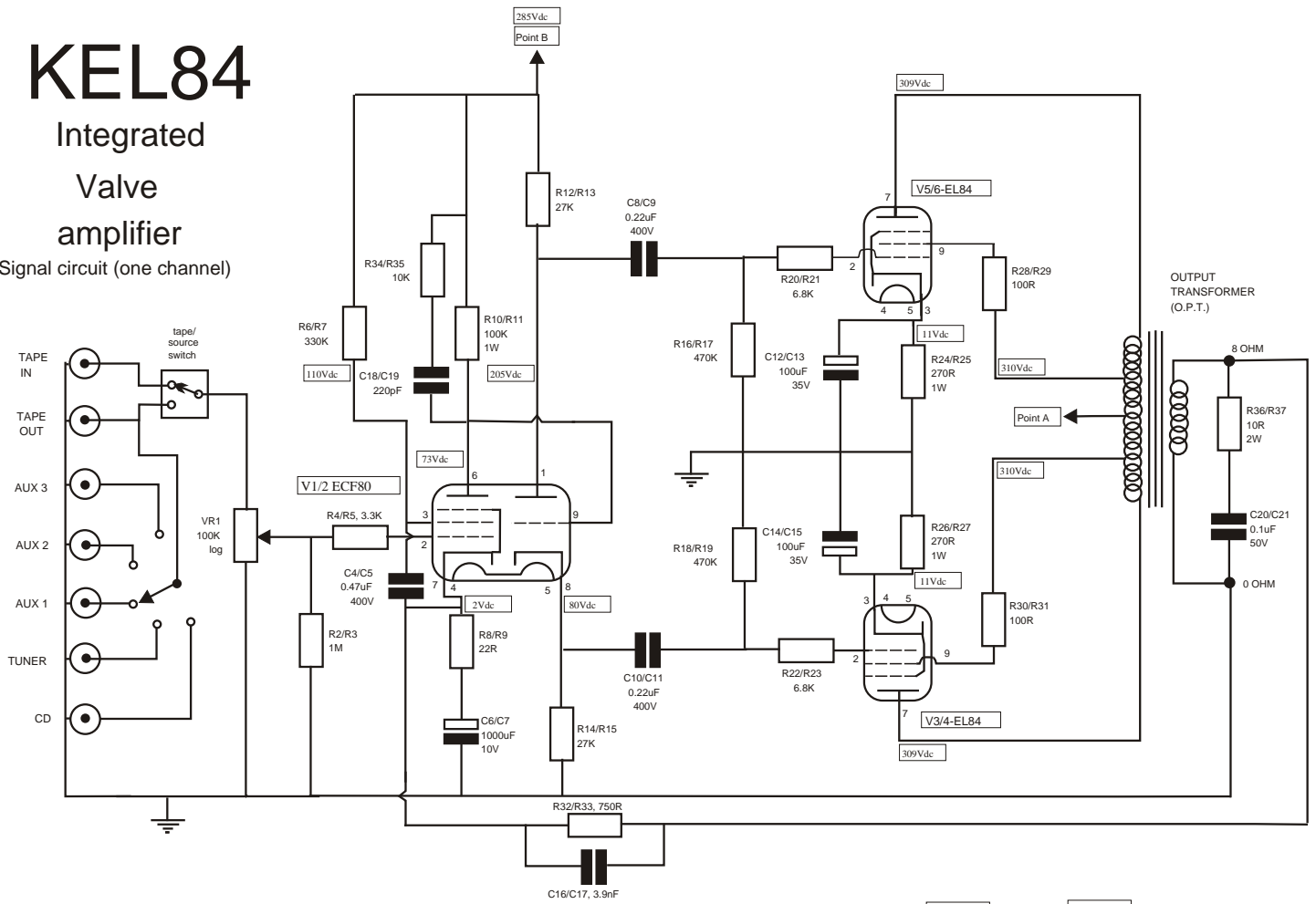

Power supply unit (both channels)

For 230V/240V operation join windings in series, join violet & grey together and insulate. Brown is 230V/240V and blue is 0V.

For 110V/120V operation join windings in parallel, join brown & grey together becoming 110V/120V and blue and violet together becoming is 0V.

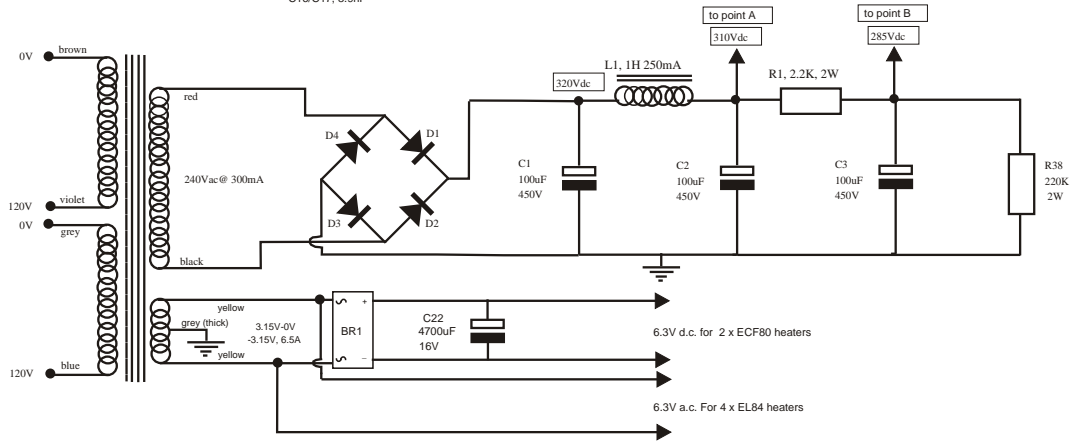

VALVE PIN LAYOUT

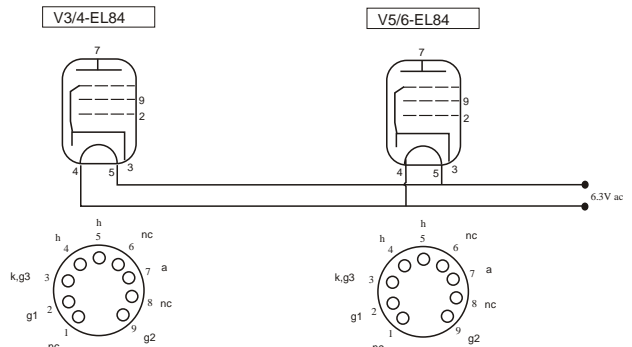
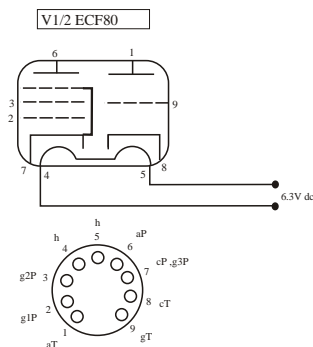

Views are from underneath valve or valve holder
 h = heater hct = heater centre tap c = cathode a = anode g1 = grid 1 g2 = grid 2 g3 = grid 3 nc = no connection (T=triode P=pentode for V1)